

Nokia Reaction Bluetooth Headset User Guide

Issue 1.0

Contents

Introduction	3
About your headset	3
About Bluetooth connectivity	3
Get started	4
Keys and parts	4
Wear the headset	4
Switch the headset on or off	6
Use your headset for the first time	6
Charge the battery	6
Pair the headset	8
Pair your headset with your phone	8
Pair with a phone with NFC	8
Pair the headset with another phone	9
Make calls	9
Make and receive calls	9
Adjust the volume	10
Handle calls from two phones	11
Update the software of your headset	12
Change the language of the voice guidance	12
Setting	12
Switch the voice guidance or ear detection off	12
Restore factory settings	12
Support	12
Product and safety information	13

Introduction

About your headset

With the Nokia Reaction Bluetooth Headset, you can make and receive calls hands-free. You can pair with 4 compatible phones or other devices, and can connect to 2 at the same time.

The surface of this product is nickel-free.

Warning:

This product may contain small parts. Keep them out of the reach of small children.

Parts of the product are magnetic. Metallic materials may be attracted to the product. Do not place credit cards or other magnetic storage media near the product, because information stored on them may be erased.

Read this user guide carefully before using the product. Also, read the user guide for the device that you connect to the product.

About Bluetooth connectivity

You can use Bluetooth to make a wireless connection to other compatible devices, such as mobile phones.

Devices do not need to be in direct line-of-sight, but they must be within 10 meters (33 feet) of each other. The connection may be affected by obstructions such as walls or other electronic devices.

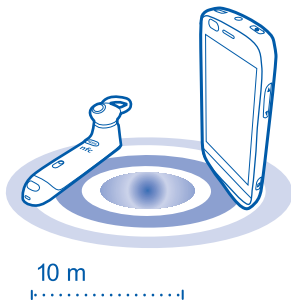

This device is compliant with Bluetooth Specification 3.0 supporting the following profiles: hands-free (1.6), headset (1.2), advanced audio distribution (1.2), and audio/

video remote control (1.4) . Check with the manufacturers of other devices to determine their compatibility with this device.

Get started

Keys and parts

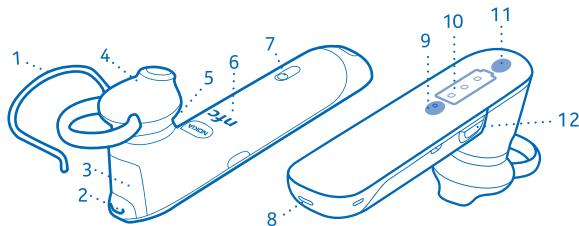

- 1 Earloop (optional)
- 2 Call key
- 3 Micro-USB connector
- 4 Earpad
- 5 Earpiece
- 6 NFC area
- 7 Power switch
- 8 Microphone
- 9 Volume down
- 10 Battery indicator
- 11 Volume up
- 12 Menu key

Wear the headset

Put the headset to your ear so that the hole in the earpad is directly toward your ear canal and the hoop of the earpad is diagonally toward the top of your head. Point the headset toward your mouth.

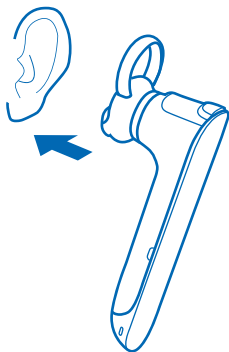

Your headset comes with several different-sized earpads – select the one that fits the best, and is the most comfortable for your ear.

Change the earplug

Pull the current earpad from the earpiece, then push the new earpad into place.

Tip: If you'd like the headset to be more firmly against your ear, attach the optional earloop to the earpiece, then slip the earloop over your ear.

When you're not using your headset, keep it in the carrying clip – the headset switches off automatically. You can attach the clip to your clothing.

Switch the headset on or off

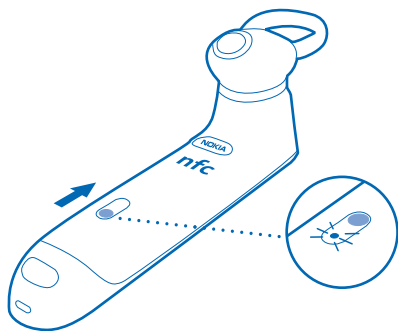

Switch on

Slide the power switch toward the earpiece.

Tip: The headset goes into power save mode when you're not wearing it. When you put the headset back to your ear, it reconnects to your phone.

Switch off

Slide the power switch away from the earpiece, or put the headset into the carrying clip.

Use your headset for the first time

Voice prompts guide you through setting up your headset when you switch the headset on for the first time.

- 1 Switch the headset on.
- 2 Put the headset to your ear.
- 3 Follow the voice prompts to pair the headset with your phone.

Tip: You can change the language of the voice prompts with the Nokia accessory software updater app.

Charge the battery

The headset has been charged at the factory, but you may want to recharge it before you switch the headset on for the first time.

Warning:

Use only chargers approved by Nokia for use with this particular model. The use of any other types may invalidate any approval or warranty, and may be dangerous. Use of unapproved chargers may present a risk of fire, explosion, or other hazard.

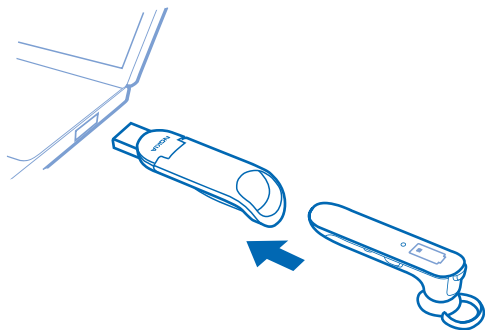

- 1 Put the headset in the charging adapter.
- 2 Connect the adapter to a USB port on your computer, or to a compatible charger. The lights in the battery indicator blink slowly when your headset is being charged. When the indicator lights stop blinking, the battery is fully charged.

The fully charged battery has power for up to 6 hours of talk time. The standby time is up to 12–15 days. When in the carrying clip, the standby time is up to 3 months.

When the battery charge is low, the frame around the battery indicator blinks.

Check the battery level

Make sure the headset is on, then swipe your finger over the battery indicator. The three white indicator lights show the battery level. If the headset is in your ear, a voice prompt tells you the remaining talk time.

Tip: You can charge your headset also without the charging adapter. Use a compatible USB cable to connect the headset to your computer or a charger.

When you unplug a charger, hold and pull the plug, not the cord.

Pair the headset

Pair your headset with your phone

Before using the headset, you must pair and connect it to a compatible Bluetooth device, such as your phone. You can't pair the headset with a phone during a call.

Follow these instructions when you are pairing your first device, or if you have restored the factory settings.

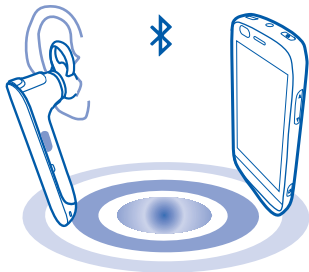

- 1 On your phone, switch Bluetooth on.
- 2 Switch the headset on, then put the headset to your ear. You are guided with voice prompts.
- 3 If your headset is not shown on your phone, search for new devices, then select the headset.
- 4 If asked for a passcode on your phone, type in **0000**.

Set your headset as a trusted device to make it connect to your phone automatically.

With some phones, you may need to make the connection separately after pairing.

Pair with a phone with NFC

If your phone supports Near Field Communication (NFC), it is easy to pair your headset.

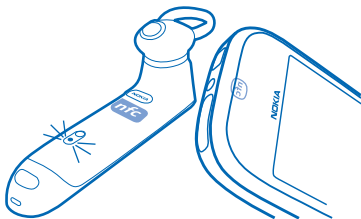

- 1 On your phone, make sure that NFC is on and the phone keys and screen are unlocked.
- 2 Switch the headset on.
- 3 Tap the NFC area of the headset with the NFC area of the phone.

Set your headset as a trusted device to make it connect to your phone automatically.

Pair the headset with another phone

After pairing your headset with your phone, you can pair it with up to 3 other phones. The headset can be connected to 2 phones at the same time, so you can make and receive calls on, for example, your personal and your work phone at the same time.

- 1 On the phone you want to pair with, switch Bluetooth on.
- 2 Switch the headset on, then put it to your ear.
- 3 Press and hold the menu key, then follow the voice prompts.

As well as pairing with a phone, you can also switch ear detection and voice guidance off, and restore factory settings.

Make calls

Make and receive calls

Make sure your headset is on, and that your headset is a trusted device in your phone Bluetooth settings – so the headset connects to your phone automatically when needed.

Most features can be handled with the call key  on your headset.

Make a call

Put the headset to your ear, then make a call in the normal way.

Answer a call

Put the headset to your ear.

If the headset is already in your ear, press .

End a call

Press .

Decline a call

Decline the call as you normally would on your phone.

If the headset is in your ear, press  twice.

Mute or unmute a call

Press the menu key on the headset.

Switch a call from your phone to your headset

Put the headset to your ear.

Switch a call from your headset to your phone

Take the headset from your ear.

When no call is in progress, you can redial the number you last called or use your voice to make a call, if your phone supports these features with the headset.

Redial the last called number

Press  twice.

Use voice dialing

Press and hold , then follow the instructions in the phone user guide.

Adjust the volume

Your headset listens to the background noise, and changes the volume automatically.

**Manually turn the volume up**

Tap the end of the headset closer to the earpiece.

Manually turn the volume down

Tap the dot in the middle of the headset.

Tip: To quickly change the volume, tap and hold instead of tapping.

Handle calls from two phones

If your headset is connected to 2 phones, you can handle calls from both phones at the same time. You can control the incoming calls on your phones or on the headset.

End an ongoing call, then answer a call on another phone

Press .

Decline a call on another phone without ending an ongoing call

Press  twice.

Put an ongoing call on hold, then answer a call on another phone

Press and hold .

Switch between active and held calls

Press and hold .

End an ongoing call, then switch to a held call

Press .

If you redial or use voice dialing, the call is made on the phone you last had an active call on with the headset.

Update the software of your headset

- 1 On your computer, download and install the Nokia accessory software updater app from www.nokia.com/support.
- 2 Your headset came with a USB cable. Open the USB cover, connect the micro-USB end of the cable to the headset, then connect the standard USB end to your computer.
- 3 Open the updater app, then follow the instructions shown on your computer. Do not unplug the USB cable during the software update.

Change the language of the voice guidance

Open the app used to update the software of your headset, then follow the instructions shown on your computer. You do not need to update the software.

Setting

Switch the voice guidance or ear detection off

If you'd prefer to use your headset without the voice prompts or the feature that detects when the headset is in your ear, you can switch them off.

- 1 Put the headset to your ear.
- 2 Press and hold the menu key on the headset.
- 3 When asked to switch the ear detection on or off, press the menu key.
- 4 When asked to switch the voice guidance on or off, press the menu key.

To listen to the voice prompts again, press and hold the menu key.

Restore factory settings

- 1 Switch the headset on, then put the headset to your ear.
- 2 Press and hold the menu key, then follow the voice prompts.

After restoring the factory settings, you need to pair the headset with your phones and other devices again.

Support

When you want to learn more about how to use your device, or if you're unsure how your device should work, read the user guide thoroughly.

If you have an issue, restore the original factory settings.

If your issue remains unsolved, contact Nokia for repair options.

Product and safety information

Battery and charger information

This device has an internal, nonremovable, rechargeable battery. Do not attempt to remove the battery from the device as you may damage the device.

This device is intended for use when supplied with power from the following chargers: AC-16, AC-50, DC-20, and the charger adapter AD-89. The exact charger model number may vary depending on the type of plug. The plug variant is identified by one of the following: E, X, AR, U, A, C, K, or B.

The battery can be charged and discharged hundreds of times, but it will eventually wear out.

Talk and standby times are estimates only. Actual times are affected by, for example, device settings, features being used, battery condition, and temperature.

If the battery has not been used for a long time, to begin charging, you may need to connect the charger, then disconnect and reconnect it.

If the battery is completely discharged, it may take several minutes before the charging indicator is displayed.

When your charger is not in use, unplug it from the electrical plug and the device. Do not leave a fully charged battery connected to a charger, as overcharging may shorten the battery's lifetime. If left unused, a fully charged battery will lose its charge over time.

Always keep the battery between 15°C and 25°C (59°F and 77°F). Extreme temperatures reduce the capacity and lifetime of the battery. A device with a hot or cold battery may not work temporarily.

Do not dispose of batteries in a fire as they may explode. Dispose of batteries according to local regulations. Recycle when possible. Do not dispose as household garbage.

Use the charger for its intended purpose only. Improper use or use of unapproved chargers may present a risk of fire, explosion, or other hazard, and may invalidate any approval or warranty. If you believe the charger is damaged, take it to a service center for inspection before continuing to use it. Never use a damaged charger. Only use the charger indoors.

Take care of your device

Handle your device, charger and accessories with care. The following suggestions help you protect your warranty coverage.

- Keep the device dry. Precipitation, humidity, and all types of liquids or moisture can contain minerals that corrode electronic circuits. If your device gets wet, allow the device to dry.
- Do not use or store the device in dusty or dirty areas. Moving parts and electronic components can be damaged.
- Do not store the device in high temperatures. High temperatures can shorten the life of the device, damage the battery, and warp or melt plastics.
- Do not store the device in cold temperatures. When the device warms to its normal temperature, moisture can form inside the device and damage electronic circuits.
- Do not attempt to open the device.
- Unauthorized modifications may damage the device and violate regulations governing radio devices.
- Do not drop, knock, or shake the device. Rough handling can break internal circuit boards and mechanics.
- Only use a soft, clean, dry cloth to clean the surface of the device.

Recycle

Always return your used electronic products, batteries, and packaging materials to dedicated collection points. This way you help prevent uncontrolled garbage disposal and promote the recycling of materials.

Copyright and other notices

DECLARATION OF CONFORMITY

CE 0979

Hereby, NOKIA CORPORATION declares that this BH-907 product is in compliance with the essential requirements and other relevant provisions of Directive 1999/5/EC. A copy of the Declaration of Conformity can be found at <http://www.nokia.com/global/declaration>.

© 2012 Nokia. All rights reserved.

Nokia, Nokia Connecting People, and the Nokia Original Accessories logo are trademarks or registered trademarks of Nokia Corporation. Other product and company names mentioned herein may be trademarks or tradenames of their respective owners.

Reproduction, transfer, distribution, or storage of part or all of the contents in this document in any form without the prior written permission of Nokia is prohibited. Nokia operates a policy of continuous development. Nokia reserves the right to make changes and improvements to any of the products described in this document without prior notice.

The Bluetooth word mark and logos are owned by the Bluetooth SIG, Inc. and any use of such marks by Nokia is under license.

To the maximum extent permitted by applicable law, under no circumstances shall Nokia or any of its licensors be responsible for any loss of data or income or any special, incidental, consequential or indirect damages howsoever caused.

The contents of this document are provided "as is." Except as required by applicable law, no warranties of any kind, either express or implied, including, but not limited to, the implied warranties of merchantability and fitness for a particular purpose, are made in relation to the accuracy, reliability or contents of this document. Nokia reserves the right to revise this document or withdraw it at any time without prior notice.

The availability of some features may vary by region. Please contact your operator for more details.

The availability of products may vary by region. For more information, contact your Nokia dealer. This device may contain commodities, technology or software subject to export laws and regulations from the US and other countries. Diversion contrary to law is prohibited.

FCC/INDUSTRY CANADA NOTICE

This device complies with part 15 of the FCC rules and Industry Canada license-exempt RSS standard(s). Operation is subject to the following two conditions: (1) This device may not cause harmful interference, and (2) this device must accept any interference received, including interference that may cause undesired operation. Your device may cause TV or radio interference (for example, when using a device in close proximity to receiving equipment). If you require assistance, contact your local service facility. Any changes or modifications not expressly approved by Nokia could void the user's authority to operate this equipment.

NOTE: FCC Radiation Exposure Statement: This equipment complies with FCC radiation exposure limits set forth for an uncontrolled environment. This transmitter must not be co-located or operating in conjunction with any other antenna or transmitter.

/Issue 1.0 EN-US